

Up to 340 mW Fiber Bragg Grating Stabilized 980 nm Pump Modules

S26 Series

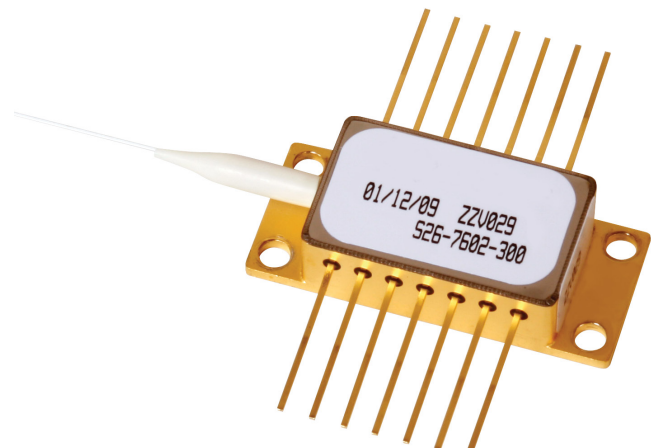

The Lumentum S26 Series pump laser module uses a revolutionary design and lean manufacturing processes to significantly advance the performance and scalability of 980 nm pumps. The semicooled 45°C laser diode operation provides for a significant reduction in TEC and overall power consumption. The module meets the stringent requirements of the telecommunications industry including Telcordia GR-468-CORE for hermetic 980 nm pump modules.

The S26 Series pump module, which uses fiber Bragg grating stabilization to lock the emission wavelength, provides a noise-free, narrowband spectrum even under changes in temperature, drive current, and optical feedback. Wavelength selection is available for applications requiring the highest performance in spectrum control with the highest power available.

Key Features

- Operating power range from 100 – 340 mW
- Reduced TEC power consumption compatible with legacy temperature control
- Low-profile, 14-PIN butterfly package
- Fiber Bragg grating stabilization
- Wavelength selection available
- Integrated thermoelectric cooler, thermistor, and monitor diode
- High dynamic range
- Excellent low power stability

Applications

- Dense wavelength division multiplexing (DWDM) EDFAs for small package designs
- High bit-rate and high channel-count EDFAs
- CATV distribution

Compliance

- Telcordia GR-468-CORE

Dimensions Diagram

(Specifications in mm unless otherwise noted; tolerance = x. ±0.3, x.x ±0.25.)

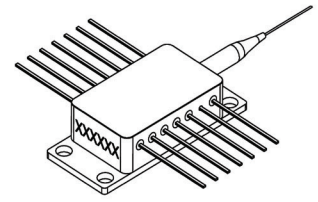
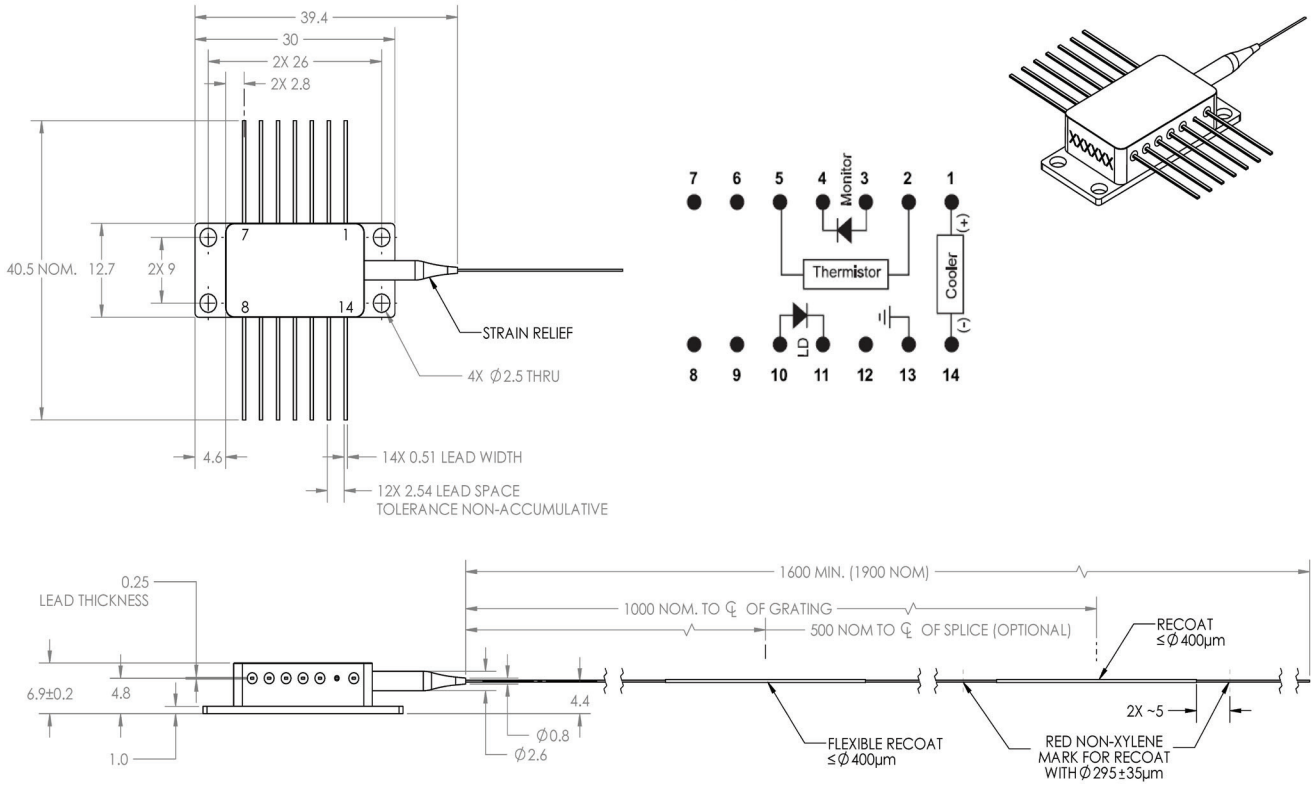

Pinout

Pin	Description
1	Cooler (+)
2	Thermistor
3	Monitor PD anode
4	Monitor PD cathode
5	Thermistor
6	N/C
7	N/C
8	N/C
9	N/C
10	Laser anode
11	Laser cathode
12	N/C
13	Case ground
14	Cooler (-)

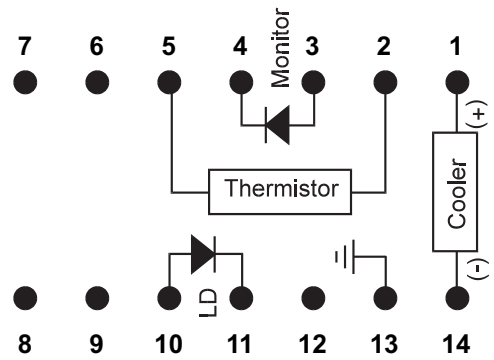

Table 1. Absolute Maximum Ratings

Parameter	Symbol	Test Conditions	Minimum	Maximum
Operating case temperature	T_{OP}		-5°C	75°C
Storage temperature	T_{STR}	2000 hr	-40°C	85°C
Laser operating temperature	T_{LD}		-5°C	50°C
LD reverse voltage	V_r			2 V
LD forward current	$I_{r,max}$	48 hr maximum		1000 mA
LD reverse current				10 μ A
PD reverse voltage	V_{PD}			20 V
PD forward current	I_{PF}			10 mA
LD electrostatic discharge (ESD)	V_{ESDLD}	C = 100 pF, R = 1.5 k Ω , human body model		1000 V
PD electrostatic discharge (ESD)	V_{ESDPD}	C = 100 pF, R = 1.5 k Ω , human body model		700 V
TEC current	I_{TEC}		-0.75 A	1.5 A
TEC voltage	V_{TEC}			2.5 V
Axial pull force		3 x 10 s		5 N
Side pull force		3 x 10 s		2.5 N
Fiber bend radius			16 mm	
Relative humidity	RH	Noncondensing	5%	95%
Lead soldering time		300°C		10 s

Absolute maximum ratings are the maximum stresses that may be applied to the module for short periods of time without causing damage. Stresses in excess of the absolute maximum ratings can cause permanent damage to the device. Exposure to absolute maximum ratings for extended periods of time or exposure to more than one absolute maximum rating simultaneously may adversely affect device reliability. Specifications may not necessarily be met under these conditions.

Table 2. Operating Parameters (BOL, $T_{case} = -5$ to 75°C, -50 dB reflection, unless otherwise noted.)

Product Code	Maximum Operating Power P_{op} (mW)	Maximum Operating Current I_{op} (mA)	Minimum Kink-Free Power P_{max} (mW)	Maximum Kink-Free Current I_{max} (mA)
S26-xxxx-100	100	230	110	255
S26-xxxx-120	120	275	130	300
S26-xxxx-140	140	320	155	355
S26-xxxx-160	160	365	175	395
S26-xxxx-180	180	405	200	455
S26-xxxx-200	200	450	220	500
S26-xxxx-220	220	495	240	540
S26-xxxx-240	240	535	265	595
S26-xxxx-260	260	580	285	645
S26-xxxx-280	280	625	310	700
S26-xxxx-300	300	670	330	740
S26-xxxx-320	320	720	350	790
S26-xxxx-340	340	765	375	855

The xxxx denotes the wavelength per the product code in Table 3.

Table 3. Available Peak Wavelength Selection

Product Code	Minimum Center Wavelength	Maximum Center Wavelength
S26-7402-yyy	973.0 nm	975.0 nm
S26-7602-yyy	975.0 nm	977.0 nm
S26-8000-yyy	973.0 nm	981.5 nm

The yyy denotes the power per the product code in Table 2.

Table 4. Electro-Optical Performance (BOL, $T_{\text{case}} = -5$ to 75°C , $P_f = 20$ mW to P_{max} , -50 dB reflection, unless otherwise noted.)

Parameter	Symbol	Test Conditions	Minimum	Maximum
Threshold current	$I_{\text{th-BOL}}$			35 mA
Forward voltage	V_f	$I_f = I_{\text{op}}$		2.5 V
Fiber output power range	P_f		20 mW	P_{op}
Pump power in band	P_{pump}	P_{pump} Band = $\lambda_c \pm 1.5$ nm, at P_{op}	90%	
Spectral width	$\Delta\lambda_{\text{RMS}}$	50 mW < $P < P_{\text{op}}$		2.0 nm
Wavelength tuning vs. temperature	$\Delta\lambda/T$	$I_f = I_{\text{op}}$		0.01 nm/ $^{\circ}\text{C}$
Optical power stability	$\Delta P_{f,t}$	Over P_f range, DC to -50 kHz		
		5 mW < $P_f < 12$ mW		10%
		12 mW < $P_f < 20$ mW		2.0%
		20 mW to P_{op}		1.0%
Tracking ratio ¹	TR	$0.1P_{\text{op}} < P_f < P_{\text{op}}$	0.75	1.25
Tracking error ²	TE	At P_{op}	-25%	25%
Monitor diode responsivity	I_{BF}	At P_{op} , $V_{\text{PD}} = -5$ V	1 $\mu\text{A}/\text{mW}$	5 $\mu\text{A}/\text{mW}$
Thermistor resistance	R_{th}	$T_{\text{set}} = 45^{\circ}\text{C}$	9.5 k Ω	10.5 k Ω
		$T_{\text{set}} = 25^{\circ}\text{C}$	21.7 k Ω	24.0 k Ω
Thermistor constant	B		3600 K	4200 K

1. The tracking ratio is a measure of the front-to-back tracking when the output power is varied. On a plot of optical power versus back-face photocurrent, a straight line is drawn between the minimum power (20 mW) and the operating power (P_{op}) points. The tracking ratio is defined as the ratio between measured optical power (shown as data points on the plot) to the value derived from the straight line.

2. The tracking error is defined as the normalized change of output power relative to the operating power over case temperature range (0 to 75°C), at constant back-face monitor current corresponding to the operating power at 25°C .

Table 5. TEC and Total Module Power Consumption (BOL for $\Delta T = 30^{\circ}\text{C}$, $T_{\text{case}} = 75^{\circ}\text{C}$, $T_{\text{LD}} = 45^{\circ}\text{C}$)

Product Code	TEC Current I_{max} (A)	TEC Voltage V_{max} (V)	TEC Power Consumption P_{TEC} (W)	Total Module Power Consumption P_{max} (W)
S26-xxxx-100	0.55	1.01	0.50	0.81
S26-xxxx-120	0.58	1.03	0.55	0.93
S26-xxxx-140	0.61	1.05	0.59	1.04
S26-xxxx-160	0.63	1.08	0.63	1.15
S26-xxxx-180	0.65	1.10	0.67	1.27
S26-xxxx-200	0.68	1.12	0.70	1.39
S26-xxxx-220	0.71	1.15	0.75	1.52
S26-xxxx-240	0.74	1.18	0.80	1.66
S26-xxxx-260	0.77	1.22	0.86	1.82
S26-xxxx-280	0.81	1.26	0.94	2.00
S26-xxxx-300	0.86	1.30	1.03	2.21
S26-xxxx-320	0.92	1.35	1.15	2.44
S26-xxxx-340	0.98	1.41	1.30	2.71

Table 6. HI 1060 Fiber Nominal Characteristics and Tolerances

Parameters	Specification
Cutoff wavelength	920 nm
Maximum attenuation at 980 nm	2.1 dB/km
Cladding outside diameter	125 ±1 μm
Coating outside diameter	245 ±10 μm
Core-cladding concentricity	≤0.5 μm
Mode field diameter	5.9 ±0.3 μm

User Safety

Safety and Operating Considerations

The laser light emitted from this laser diode is invisible and may be harmful to the human eye. Avoid looking directly into the fiber when the device is in operation.

CAUTION: THE USE OF OPTICAL INSTRUMENTS WITH THIS PRODUCT INCREASES EYE HAZARD.

Operating the laser diode outside of its maximum ratings may cause device failure or a safety hazard. Power supplies used with this component cannot exceed maximum peak optical power.

CW laser diodes may be damaged by excessive drive current or switching transients. When using power supplies, the laser diode should be connected with the main power on and the output voltage at zero. The current should be increased slowly while monitoring the laser diode output power and the drive current. Careful attention to heatsinking and proper mounting of this device is required to ensure specified performance over its operating life. To maximize thermal transfer to the heatsink, the heatsink mounting surface must be flat to within .001inch and the mounting screws must be torqued down to 1.5 in/lb.

ESD PROTECTION—Electrostatic discharge (ESD) is the primary cause of unexpected laser diode failure. Take extreme precaution to prevent ESD. Use wrist straps, grounded work surfaces, and rigorous antistatic techniques when handling laser diodes.

Labeling

Laser Safety

The Lumentum pump laser module emits hazardous invisible laser radiation.

Due to the small size of the pump module, the box packaging is labeled with the laser radiation hazard symbol and safety warning labels shown.

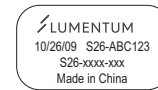

14-pin module label



Shipping box label



Output power and laser emission indicator label

Ordering Information

For more information on this or other products and their availability, please contact your local Lumentum account manager or Lumentum directly at customer.service@lumentum.com.

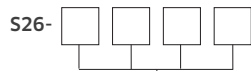

Peak Wavelength	Code
973.0 to 975.0 nm	7402
975.0 to 977.0 nm	7602
973.0 to 981.5 nm	8000

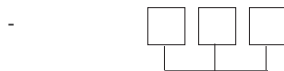

Maximum Operating Power	Code
100 mW	100
120 mW	120
140 mW	140
160 mW	160
180 mW	180
200 mW	200
220 mW	220
240 mW	240
260 mW	260
280 mW	280
300 mW	300
320 mW	320
340 mW	340

Telcordia is a registered trademark of Telcordia Technologies Incorporated.



North America
Toll Free: 844 810 LITE (5483)

Outside North America
Toll Free: 800 000 LITE (5483)

China
Toll Free: 400 120 LITE (5483)

© 2015 Lumentum Operations LLC
Product specifications and descriptions in this document are subject to change without notice.